

AKU143

Analog Silicon MEMS Microphone

www.akustica.com



General Description

AKU143 is an HD Voice quality, top port, analog output MEMS semiconductor microphone. It is a microphone consisting of a MEMS acoustic sensor, and an integrated circuit (IC) with a pre-amplifier, charge pump, and supporting circuitry in an industry standard package footprint of 2.95mm x 3.76mm x 1.10mm.

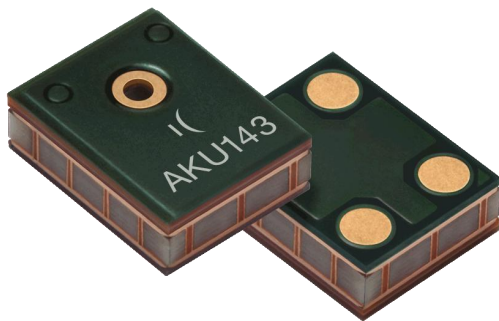

Designed specifically to meet the demanding requirements of mobile handset OEMs, AKU143 offers excellent acoustic performance with 65dB signal-to-noise ratio (SNR) and uniform sensitivity matching of just ± 1 dB between microphones. Unlike other top port analog microphones, AKU143 offers a flat wideband frequency response, with deviations less than 5dB from 50Hz to 14kHz, delivering uniform audio capture across a broad acoustic spectrum. The AKU143 Faraday-cage constructed package is immune to RF and Electromagnetic (EM) interferences, allowing for easy integration into wireless devices.

Key Features

- ▶ Top port, Analog output
- ▶ Omni-directional silicon microphone
- ▶ Excellent acoustic performance: 65dB SNR
- ▶ Uniform sensitivity tolerance: -42dB ± 1 dB
- ▶ Flat frequency response for super-wideband audio
- ▶ Package immune to RF/EM interference
- ▶ Lead-free, surface-mountable and RoHS2 compliant
- ▶ Halogen-free in accordance with IEC61249-2-21
- ▶ Thin profile, SMT packaging
- ▶ Industry-standard package of: 2.95x3.76x1.10mm³
- ▶ Built-in support for 2-wire mode

Target Applications

- ▶ Smartphones and mobile phones
- ▶ Digital still/video cameras
- ▶ Portable media players
- ▶ Gaming consoles / controllers
- ▶ Voice activated entertainments systems and remote controllers
- ▶ Smart-home sensor hubs / clusters, and IoT acoustic sensor nodes
- ▶ Microphone arrays – multi-mic applications

Functional Block Diagram

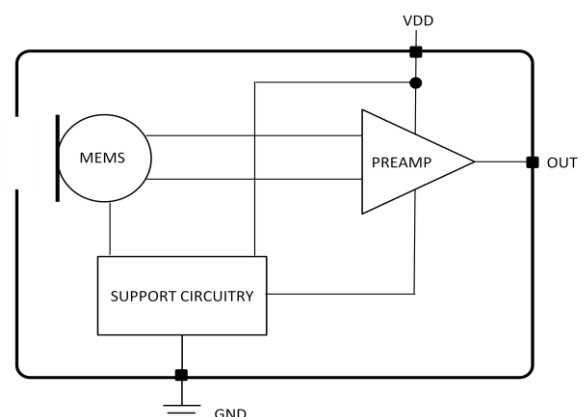

Technical Specifications

Operating voltage	1.62V to 3.6V
Directivity	Omni-directional
SNR	65dB
Sensitivity	-42dBV/Pa ± 1dBV
Flat Frequency Response (± 5dB)	50Hz to 14kHz
PSRR	60dB
Current Consumption	155µA
Port Location	Top
Package Dimensions	2.95x3.76x1.10mm ³

Akustica Advantages

Multiple MEMS Technologies: Akustica has two completely different MEMS technologies to choose from, uniquely positioning Akustica as a development partner for next generation products that meet the diverse size and performance requirements of consumer electronics device manufacturers.

In-house Design and Manufacturing: Unlike other MEMS microphone manufacturers who buy their MEMS and/or ASIC die from a third party, Akustica maintains complete product knowledge by designing 100% of our MEMS microphones in-house. In addition, Akustica is the only MEMS microphone supplier to offer the security of in-house MEMS manufacturing via Bosch's world-renowned wafer fab in Reutlingen, Germany.

Applications Expertise: The performance of modern microphone systems is heavily dependent on the overall platform design, including software algorithms, mechanical layout and hardware implementation. As an innovator in the field of MEMS microphones and leveraging over 10 years of experience, Akustica has a deep understanding of acoustic design requirements and proper analysis methods. To ensure our customers a seamless integration experience and support constrained design cycles, Akustica offers acoustic design and modeling services prior to assembly. Akustica also provides production test services, training, and test equipment to help ensure the quality of both incoming and final assembled products.

Typical Frequency Response

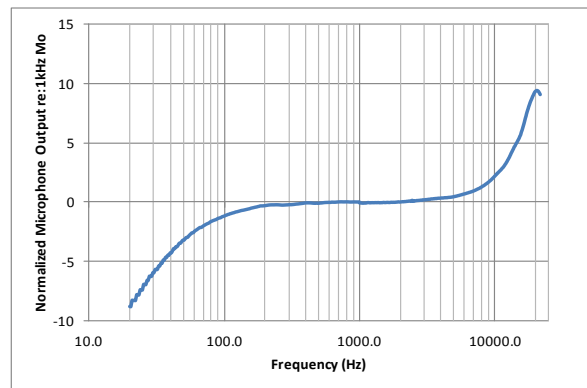

About Akustica – Bosch Group

Akustica was founded in 2001 to develop and market a complete portfolio of digital and analog microphones using the unique and patented CMOS MEMS technology developed at Carnegie Mellon University. In 2009, Akustica was acquired by, and is now a wholly owned subsidiary of, Robert Bosch North America. As part of the Bosch Group, Akustica joins a family of companies with combined annual sales of more than \$70 billion and a footprint of over 300,000 associates worldwide.

Bosch has been active in the field of MEMS since 1988 and is one of the pioneers in microsystem-technology. Bosch serves both the automotive and consumer electronics markets, and is the only MEMS supplier to design and manufacture all of its own MEMS for its complete portfolio of inertial, pressure, magnetic, and acoustic MEMS sensors for consumer devices. With more than four billion MEMS sensors shipped worldwide since 1993, Bosch is the world's leading supplier of MEMS sensors.

Ordering Information

Part Number	AKU143
Description	Analog MEMS Microphone
Package	4 Pad LGA
Shipping Method	13" Reel
Standard Quantity	5700

Please contact Akustica for further information.

Akustica, Inc.

2835 East Carson Street, Suite 301
Pittsburgh, PA 15203 USA

sales: sales@akustica.com

ph: (412) 390-1730 fx: (412) 390-1737

www.akustica.com